



DISINFECTING EQUIPMENT



Prevail™ is a member of the Virox family of brands.

Prevail® Disinfectants, powered by Accelerated Hydrogen Peroxide®, is approved by Health Canada as an effective disinfectant to fight against ASFv and other deadly pathogens. Its gentle formulation is non-toxic and safe to protect your livelihood with the utmost care in mind.



DISINFECTING EQUIPMENT

This line of equipment is approved for use with Accelerated Hydrogen Peroxide® disinfectants such as Prevail™ Concentrate Disinfectant.

Each piece of equipment, when properly calibrated, allows for accurate dilution of chemical concentrate to the desired ratio.

FOAMERS

MODEL 20 SS COMBO AIRLESS FOAMER/SPRAYER

Overview

This unit is an airless foam and spray applicator featuring a quick connect chemical injector that attaches to a pressure washer outlet. This venturi unit draws and blends chemical concentrate into the water stream to create an accurately diluted solution. The solution then flows through the hose and gun to the airless foam wand which injects atmospheric air to create and project wet, clinging foam onto surfaces up close or at distances up to 25 feet with interchangeable fan and zero-degree nozzles. Quick connect the fan pattern sprayer nozzle to apply non-foaming chemicals.

Key Features

- Quick connect the airless foam wand to project wet, clinging foam
- Foam increases chemical contact time and effectiveness, and provides visual confirmation of coverage
- Foam impacts at a lower pressure than spray, allowing a pressure washer to be used on more delicate surfaces
- Use the fan pattern foam nozzle for wide coverage or the zero degree foam nozzle for increased range (up to 25")
- Quick connect the fan pattern sprayer nozzle to apply a chemical spray
- Industrial-strength, all stainless steel design ensures durability and reliable performance
- Designed for use with 3.5–5.5 GPM pressure washers
- Draws chemical out of any sized container and accurately dilutes to the required ratio
- Chemical injector at the pressure washer output eliminates the need to carry chemicals

Includes

- 3/8" quick connect machined stainless steel injector body
- 6' chemical suction tube and strainer
- 20 color-coded precision metering tips to set dilution ratios

Recommended



Water pressure varies widely. AHP1750 Test Strips are highly recommended to set up and to periodically confirm desired dilutions.

Model 20 SS Combo Airless Foamer/Sprayer

Part Number: CD001

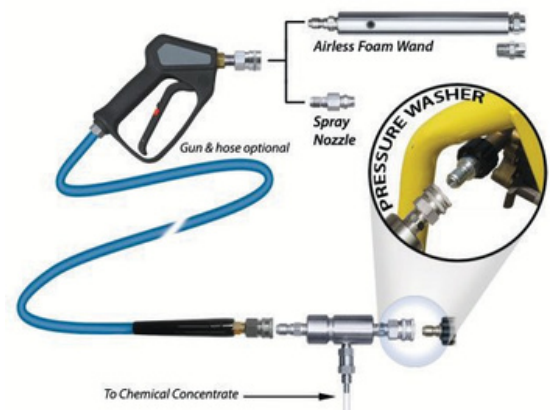

UNI-BODY A-25 AIRLESS FOAMER

Overview

This unit is a medium volume foam applicator for projecting foaming chemicals on to any surface up close or at distances up to 6 feet without compressed air. This venturi injection system uses standard city water pressure (35 - 125 PSI) to draw and blend chemical concentrate into the water stream to create an accurately diluted solution. The solution then flows through the discharge hose to the "airless" foam wand which draws in atmospheric air to create and project wet, clinging foam.

Key Features

- No compressed air required
- The unique machined polypropylene uni-body design is both compact and cost-effective
- Designed for foam cleaning small to medium sized areas
- Projects a medium volume of wet, clinging foam which increases chemical contact time and effectiveness
- Foaming expands the chemical and reduces over-application by providing visual assurance of coverage
- Projects foam up to 6' (depending on water pressure)
- Chemical resistant wetted components ensure years of outstanding performance with minimal maintenance
- Use it where 35-125 PSI water is available

Includes

- Machined polypropylene injector body
- Inlet and discharge ball valves
- 20 color-coded precision metering tips to set dilution ratios
- 50' foam hose & machined polypropylene airless foam wand

Recommended



Water pressure varies widely. AHP1750 Test Strips are highly recommended to set up and to periodically confirm desired dilutions.

A-40 AIRLESS FOAM WAND WITH FAN NOZZLE

Overview

Designed to replace the black soap nozzle on pressure washers that use a factory chemical injector. This Airless Foam Wand quick connects to a pressure washer gun and injects atmospheric air into the chemical solution to greatly increase volume and coverage ability. This stainless steel unit will create and project wet, clinging foam on to any surface in a fan pattern or zero degree stream for increased foam throw distance.

Uni-Body A-25 Airless Foamer

Part Number: CD009



A-40 Airless Foam Wand with Fan Nozzle

Part Number: CD002

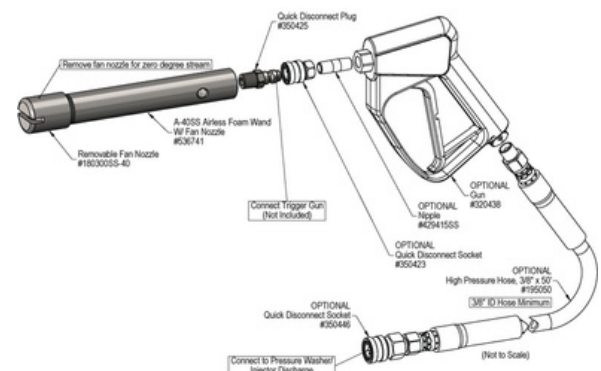

HOSE-END FOAMERS

MODEL 25 COMPACT AIRLESS FOAMER

Overview

A durable hose-end foamer for both diluting and applying Prevail onto any surface. This unit uses facility's water pressure to pull the concentrate and blend it into the water stream, which then flows through the wand to create a clinging, wet foam.

Key Features

- Attaches to standard garden hose or 1/2" water connections
- Creates rich, wet foam which increases chemical cling time and surface coverage
- Foam provides visual verification that all areas are covered
- Projects foam up to 12' (depending on water pressure)
- The stainless-steel quick connect adapter features a 6-ball socket for secure assembly
- Light, 32 oz HDPE bottle reduces wrist and arm fatigue and the risk of repetitive strain injuries
- Great performance with pressure as low as 20 PSI
- Impact resistant lid stands up to substantial abuse

Foamer Includes

- Machined polypropylene foamer body
- Quick connect adapter SS
- 32 oz wide-mouth, HDPE bottle
- Heavy-duty bottle lid
- 20 color-coded metering tips
- Garden hose gun with inlet screen/filter

Recommended



Water pressure varies widely. AHP1750 Test Strips are highly recommended to set up and to periodically confirm desired dilutions.

Model 25 Compact Airless Foamer

Part Number: CD013



DISCLAIMER

You must read and follow the instructions on the label for our product and use the product for the particular applications specified on the product label. To the full extent permitted under applicable law, Virox Technologies Inc. shall not be liable for any damages whatsoever, arising out of or otherwise in connection with any failure to follow those instructions or any use of its products which is not specified on the product's label. The instructions on the product label are not a warranty, express or implied, and Virox Technologies, Inc. expressly disclaims any implied warranties, including any warranty of fitness for a particular purpose. Under applicable law, some of the above waivers or disclaimers of warranty, or exclusions of liability for certain types of damages may not apply to you. In such cases, our liability will be limited to the fullest extent permitted by applicable law.



Contact ethoguard.com to order.

ACCESSORIES

Disinfecting Accessories

Our disinfecting accessories make chemical management simpler, neater, cleaner, and safer.

Each accessory is suggested for use with Accelerated Hydrogen Peroxide® disinfectants such as Prevail™ Concentrate and Prevail™ Ready to Use Disinfectants.

These convenient accessories complement our wide range of disinfecting equipment.



3.78L Pump

Part Number: CD003

An approved pump for the Prevail 3.78L bottle to dispense the concentrate solution into a measuring cup.



18.9L Pump

Part Number: CD004

An approved pump for the Prevail 18.9L pail to dispense the concentrate solution into a measuring cup.



200L Pump

Part Number CD005

An approved pump for the Prevail 200L drum to dispense the concentrate solution into a measuring cup. This pump dispenses 14oz of solution per stroke.



1L Trigger Sprayer/Foamer

Part Number: CD006

Applies Prevail Ready to Use or diluted concentrate solutions in a foam or aerosolized solution. Foaming is an alternative to an aerosolized spray which results in visible surface coverage and slower evaporation.



1L Empty Bottle

Part Number: CD007

Empty bottle to dispense Ready to Use or diluted concentrate and prepare for application.



AHP1750 Test Strips

Part Number: 1750

AHP1750 test strips are used to test and confirm the dilutions. These strips are easy-to-use dip-and-read strips and will confirm the 1:40 and 1:128 dilutions. (50 test strips)



Workplace Labels

(Secondary Product Labels)

Concentrate Part Number: CD019

Ready to Use, Part Number: CD029

Workplace labels are designed for secondary bottles containing diluted Prevail Concentrate solution or dispensing Prevail Ready to Use. Labels are used to identify the expiry date, lot number and dilution rate for diluted concentrates.



Metering Tips

Part Number: 909-HDP009

For use with compact airless foamers and mixing stations to ensure accurate dilutions based on facility water pressure.

PREvail®

FARM DISINFECTANTS



Ideal for disinfection and cleaning of:

- Agricultural farms and barns
- Transportation vehicles

CONCENTRATE

5 min contact time

Prevail™ Concentrate is ideal for large surfaces, providing a cost effective option for daily use.

- Easy to dilute and apply: use a 1:40 dilution (25 mL/L) for disinfection
- Long shelf life of 30 days once diluted

WIPES

1 min contact time

Prevail™ Wipes provides an easy, convenient and effective way to disinfect your smaller surfaces (e.g., inside of truck cabs, handheld equipment, steering wheels, and other high-touch surfaces).

READY-TO-USE

1 min contact time

Prevail™ Ready-to-Use is a unique pre-mixed solution that requires no dilution. Ideal for daily use and on smaller surfaces (e.g., truck cabs, boot baths, cages, and counters).

www.PrevailFarm.ca

Prevail is effective against*:

- African Swine Fever Virus (ASFv)
- Porcine Epidemic Diarrhea Virus (PEDv)
- Avian Influenza Virus
- Porcine Reproductive & Respiratory Syndrome Virus (PRRSv)

*Refer to reference sheets for a complete list of efficacy claims and use directions



POWERFUL

Proven efficacy against a broad spectrum of organisms in just 1-5 minutes. At least 2x faster than the competition.



SAFER

No harsh chemical smell and is non-irritating to eyes and skin when used as directed.



CLEANER

Formulated with powerful detergents to provide exceptional cleaning capabilities. Prevail's excellent foaming ability allows you to easily visualize surface coverage, saving time and money.

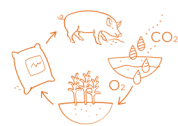

SUSTAINABLE

Biodegradable formulations – the active ingredient breaks down to water and oxygen for easy disposal and minimal environmental impact.



COMPATIBLE

Designed to be compatible with a wide range of materials, protecting assets by reducing corrosion and wear.

To Purchase Contact:



EthoGuard
Your Biosecurity Partner

www.ethoguard.com
info@ethoguard.com
tel: 226-523-5969

Contact ethoguard.com to order.



Contact ethoguard.com to order.